

Sensor Control...

Access Control...

Power Monitor Sensor



Applications

The ability to remotely monitor power can give a huge return on investment by providing savings in both man hours and downtime. Remote monitoring capabilities eliminate the need for manual power audits as well as providing immediate alerts to potential problems. The Power Meter sensor is specifically designed to be used with AKCP's Linux based line of securityProbe units. Combining the Power Meter Sensor and securityProbe creates a fully IP enabled power monitoring product. AKCP's Power Meter sensor is more rugged in design communicating through the RS485 port and is fully integrated into the securityProbe's in its own separate web interface page. Users can be alerted when the sensor exceeds a pre-defined threshold with AKCP's industry leading notification options like: SNMP traps, email, SMS, MMS and Skype support.

Data collected over time using the Power Meter Sensor can also be viewed using the securityProbe's built in graphing tool and can be exported to external applications for analysis.

Overview

High quality, compact design and easy installation make the AKCP Power Meter Sensor an ideal monitoring solution. There are three types of the Power Meter Sensor available:

- Single Phase
- Three Phase
- CT-Type (current transformer)
- Approved according to DIN standard (DIN_43880-1988)
- Compact design
- Easy to install
- LCD display
- Record Total Active Power



Measurement and register

The AKCP PMS is capable of measuring kilowatt-hours and delivered to and received from a load. The energy accumulation register has the capacity to display 99999.999 kWh or 999999.9 kWh depending on the PMS model without overflowing.

Instantaneous power parameter measurement

It is able to instantly measure accuracy on any power parameter

- Power
- Voltage RMS
- Current RMS
- Power factor

LCD display

Most critical data can be displayed on the meters built in LCD. It can indicate both meter running status and power status.

Maximum Demand (optional)

There are two options for MD recording that can be defined in the web interface software Block mode MD interval is configurable from 5min up to 60min. Slide mode MD interval and the slide window are both configurable.

Local Communication

Measured data and PMS parameters are downloaded to the securityProbe via the RS485 port and with communication protocols of IEC62056-21 or Modbus.

Communication Time from PMS to securityProbe 5E

It is currently possible to monitor 13 readings from each 3 Phase PMS from the securityProbe 5E's web interface. It is unlikely that it would be required to monitor all 13 readings, such as the power factor, however if this is required we recommend connecting roughly five 3 Phase PMS's to a single securityProbe 5E.

Data Update Time Calculation

If all 13 readings are enabled for each of the four PMS then the sensor data update to the securityProbe 5E will be roughly 7.8 seconds. This is calculated on results from actual testing of four 3 Phase PMS's as each question/response from one PMS to the unit takes 0.15 seconds x 13 readings = 1.95 seconds x 4 PMS = 7.8 seconds total.

Each PMS can be setup to monitor up to 13 separate values as follows;

List of 3 Phase values

- 3 Voltages (each voltage phase line)
- 3 Amps (each line)
- 3 Watts (each line)
- 3 Power Factor (each line)
- 1 Kwatt-hours

Total is 13 values

	Direct connect single phase meter	Direct connect three phase meter	Transformer connect three phase meter
Accuracy	Class 1	Class 1	Class 0.5s
Voltage(V)			
Rated Voltage (Un)	100 220-240	3x57-288/100-500	3x57-288/100-500
Voltage range	-23%t~+20%Un	Wide range	Wide range
Current(A)			
Basic current	5	5	1
Maximum current	100	100	10
Starting current(mA)	0.2%*Ib	0.2%Ib	0.2%Ib
Current circuits consumption (VA)	<1.1	<1.1/phase	<0.5/phase
Voltage circuits consumption (W)	<0.3	<0.3/phase	<0.3/phase
Frequency(Hz)	50/60	50/60	50/60
Standards	IEC 62052-11 IEC 62053-21	IEC 62052-11 IEC 62053-21	IEC 62052-11 IEC 62053-21
Temperature range(C)			
Operating	-25 to +70	-25 to +70	-25 to +70
Storing	-40 to +75	-40 to +75	-40 to +75
Communication			
Standard	IEC 62056-21 Modbus	IEC 62056-21 Modbus	IEC 62056-21 Modbus
Dimensions	90 x 75 x 54	122 x 90 x 54	122 x 90 x 54

Your Distribution Partner:

Didactum® Ltd. Deutschland
Marsweg 17

48163 Muenster

Germany

Phone: +49.2501.9716355

Fax: +49.2501.9716356

eMail: info@didactum.com

Web: http://www.didactum.com

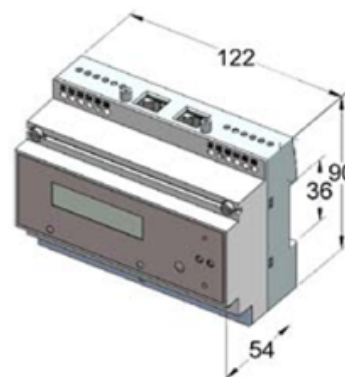
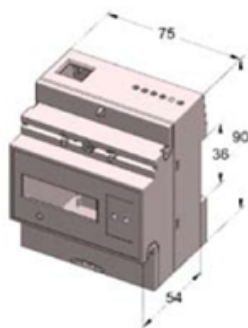

For more information, please take a look at our website, or contact Sales@akcp.com